

Subaru Select Monitor

KEYLESS ACCESS WITH PUSH BUTTON START SYSTEM (DIAGNOSTICS)

6. Subaru Select Monitor

A: OPERATION

For operation procedures, refer to the “PC application help for Subaru Select Monitor”.

B: COMMUNICATION FOR INITIALIZING IMPOSSIBLE

NOTE:

Confirm that the LAN system is working properly before the diagnosis.
Subaru Select Monitor communication line is open or shorted.

DETECTING CONDITION:

- Defective harness
- Power supply circuit malfunction
- Defective keyless access CM
- Defective CAN communication circuit
- Defective Subaru Select Monitor

TROUBLE SYMPTOM:

Not communicable with Subaru Select Monitor.

Subaru Select Monitor

KEYLESS ACCESS WITH PUSH BUTTON START SYSTEM (DIAGNOSTICS)

WIRING DIAGRAM:

- Push button start system <Ref. to WI-329, WIRING DIAGRAM, Push Button Start System.>
- CAN communication system <Ref. to WI-110, WIRING DIAGRAM, CAN Communication System.>
- Engine type: FA

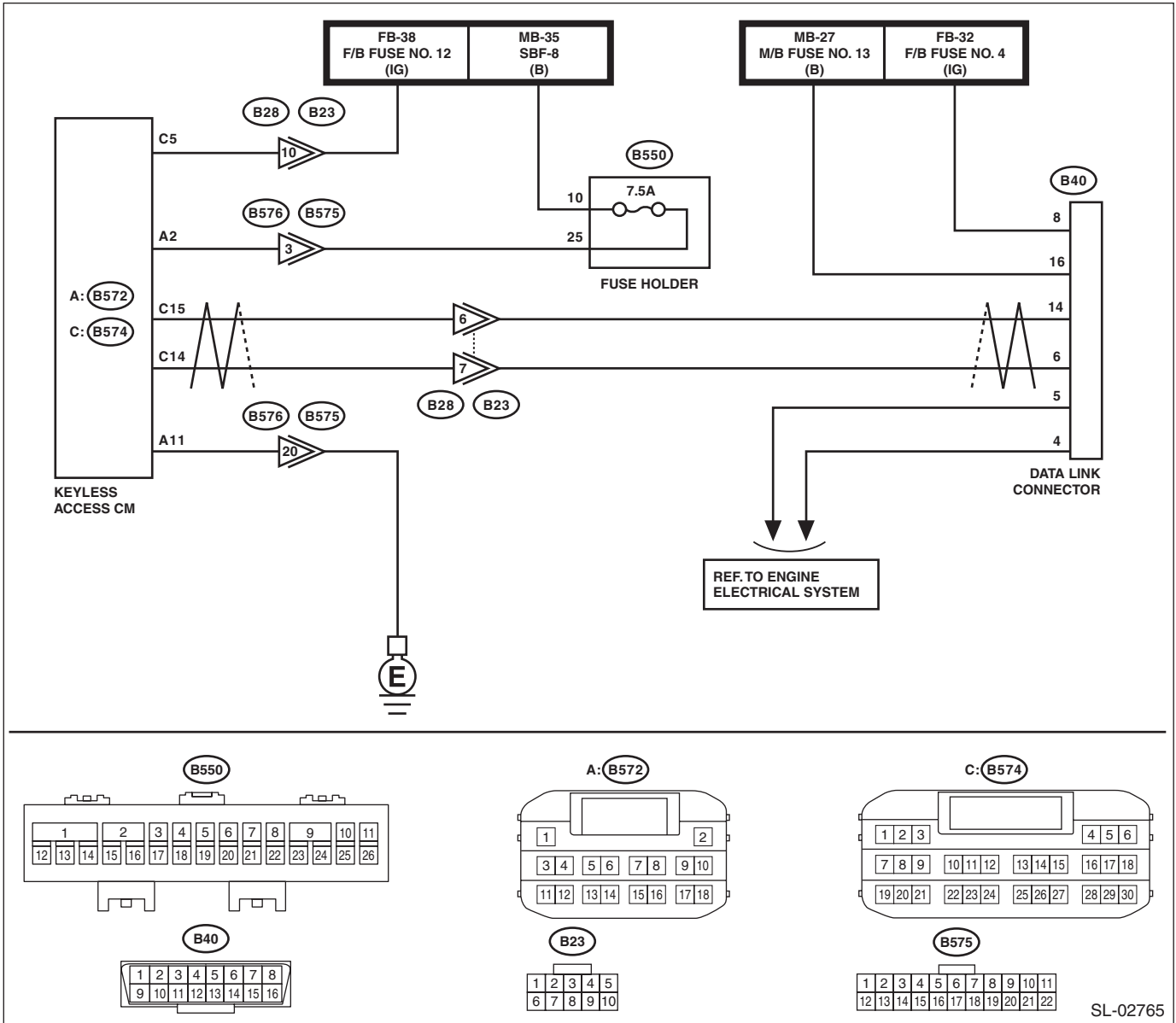

SL-02765

Subaru Select Monitor

KEYLESS ACCESS WITH PUSH BUTTON START SYSTEM (DIAGNOSTICS)

- Engine type: EJ

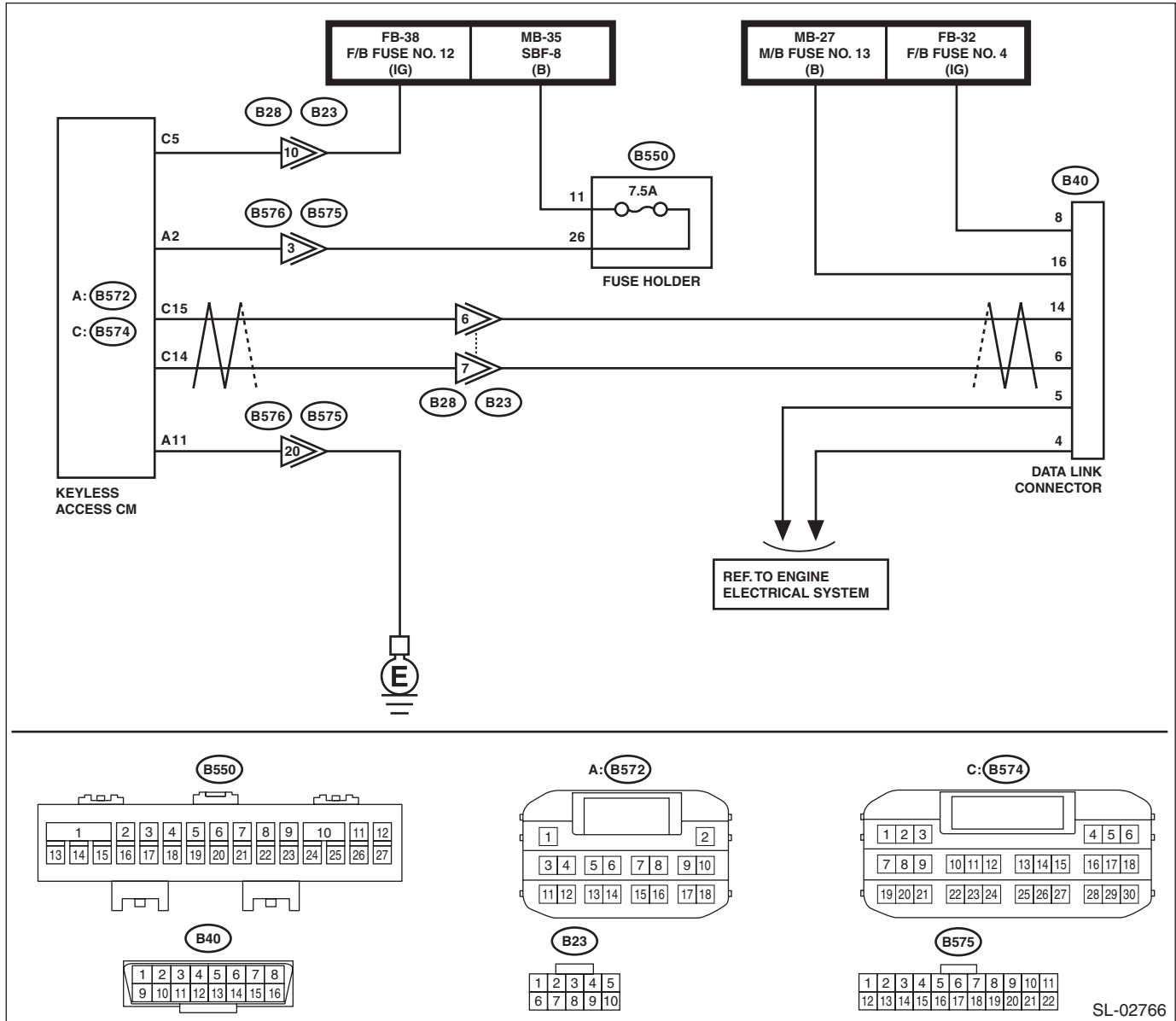

Step	Check	Yes	No
1 CHECK OTHER COMMUNICATION. Communicate with the system other than the keyless access system using the Subaru Select Monitor.	Is the communication to other control module possible?	Go to step 2.	Perform the "Communication for Initializing Impossible" of LAN system. <Ref. to LAN(diag)-11, COMMUNICATION FOR INITIALIZING IMPOSSIBLE, Subaru Select Monitor.>
2 CHECK DTC. Read the DTC of the LAN system using the Subaru Select Monitor. <Ref. to LAN(diag)-29, OPERATION, Read Diagnostic Trouble Code (DTC).>	Is DTC detected?	Perform the diagnosis according to DTC.	Go to step 3.

Subaru Select Monitor

KEYLESS ACCESS WITH PUSH BUTTON START SYSTEM (DIAGNOSTICS)

Step	Check	Yes	No
3 CHECK KEYLESS ACCESS CM. 1) Turn the ignition switch to OFF. 2) Disconnect the keyless access CM connector. 3) Connect the disconnected connectors. 4) Perform communication with the keyless access system using the Subaru Select Monitor.	Is communication possible?	It is possible that temporary poor communication occurs.	Replace the keyless access CM. <Ref. to SL-100, Keyless Access CM.>

CAUTION:

For replacement procedure of keyless access CM, refer to the “REGISTRATION MANUAL FOR IMMOBILIZER”.